

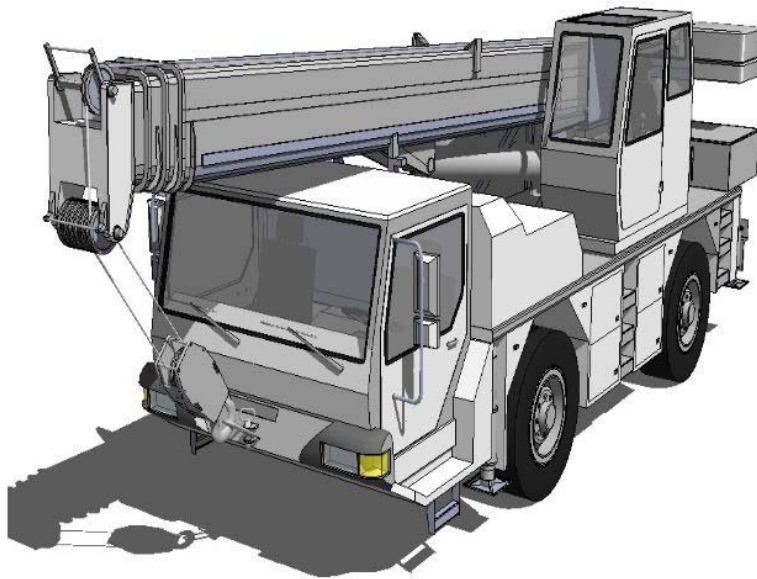

TS7000

TELESCOPIC CRANES OPERATORS MANUAL



VERSION VII
10/1/2020



THE PURPOSE OF THIS MANUAL IS TO PROVIDE THE CUSTOMER WITH THE OPERATING PROCEDURES ESSENTIAL FOR THE PROMOTION OF PROPER MACHINE OPERATION FOR ITS INTENDED USE. THE IMPORTANCE OF PROPER USAGE CANNOT BE OVERSTRESSED. ALL INFORMATION IN THIS MANUAL SHOULD BE READ AND UNDERSTOOD BEFORE ANY ATTEMPT IS MADE TO OPERATE THE MACHINE.

SINCE THE MANUFACTURER HAS NO DIRECT CONTROL OVER MACHINE APPLICATION AND OPERATION, CONFORMANCE WITH GOOD SAFETY PRACTICE IN THIS AREA IS THE RESPONSIBILITY OF THE USER AND HIS OPERATING PERSONNEL.

ALL PROCEDURES ARE BASED ON THE USE OF THE SYSTEM UNDER PROPER OPERATING CONDITIONS, WITH NO DEVIATIONS FROM THE ORIGINAL DESIGN. ALTERATION AND OR MODIFICATION OF THE EQUIPMENT IS STRICTLY FORBIDDEN WITHOUT PRIOR WRITTEN APPROVAL FROM ELEC-MECH (PTY) LTD.

THE SAFE-AID TS7000 (RATED CAPACITY INDICATOR (RCI)/LOAD MOMENT INDICATOR (LMI)) IS ONLY TO BE REGARDED AS AN AID TO THE OPERATOR. WHEN THE PARAMETERS ARE SET CORRECTLY, THE INDICATOR WILL WARN THE CRANE OPERATOR OF AN APPROACHING OVERLOAD CONDITION OR A CONDITION THAT COULD CAUSE DAMAGE TO EQUIPMENT, PROPERTY, AND/OR INJURY TO THE OPERATOR OR THE SITE WORKERS IN THE VICINITY OF THE CRANE AND ITS LOAD.

THIS SYSTEM UNDER NO CIRCUMSTANCES MUST BE USED AS A SUBSTITUTE FOR THE GOOD JUDGEMENT OF A CRANE OPERATOR WHEN CARRYING OUT APPROVED CRANE-OPERATING PROCEDURES, THEREFORE THE RESPONSIBILITY FOR THE SAFE OPERATION OF THE CRANE LIES WITH THE CRANE OPERATOR. THE SYSTEM WILL NOT NECESSARILY PREVENT DAMAGE DUE TO OVERLOADING AND RELATED CAUSES, IF NOT SET PROPERLY.

BEFORE OPERATING A CRANE EQUIPPED WITH A SAFE-AID TS7000 RCI THE OPERATOR MUST READ THE INFORMATION IN THIS MANUAL CAREFULLY. CORRECT FUNCTIONING OF THE SYSTEM DEPENDS UPON ROUTINE DAILY INSPECTION AND ANY SUSPECTED FAULTS OR APPARENT DAMAGE SHOULD BE IMMEDIATELY REPORTED TO THE RESPONSIBLE PERSON BEFORE USING THE CRANE.

Contents

SYSTEM USE – FIGURE 1	4
SYSTEM STARTUP– FIGURE 2 & 3	5
TILT OR LEVEL SET-UP– FIGURE 4	6
CRANE CONFIGURATION SELECTION	7
COUNTERWEIGHT– FIGURE 5	7
OUTRIGGER BASE– FIGURE 6.....	8
BOOM CONFIGURATION – FIGURE 7.....	9
FIFTH OUTRIGGER – FIGURE 8.....	10
WINCH – FIGURE 9.....	11
REEVING – FIGURE 10.....	12
DEDUCTIONS – FIGURE 11.....	13
OPERATING SCREENS – FIGURE 12, 13, 14 & 15	14
ERROR MESSAGES - FIGURE 16 AND TABLE #1	18
SAFE-AID TS7000 SYSTEM ERROR TABLE – TABLE #1	19
WORKING OPERATIONS – FIGURE 17 & 18	23
INDICATING STATUS LIGHTS - DUMP OUTPUT (LEVER CUT-OFF) – TABLE # 2.....	26
TOUCH SCREEN CALIBRATION – FIGURES 19, 20 & 21.....	29
WIND SPEED SETUP – FIGURES 22, 23 & 24 – OPTIONAL	31
PROGRAM & REEVING LOCKOUT – FIGURES 25, 26, 27 & 28	32
SCREEN BRIGHTNESS – FIGURES 29 & 30.....	34
SET DATE & TIME – FIGURES 31 & 32.....	35
QUICK USE FLOW CHART.....	36
INSTALLATION DETAILS	37

SYSTEM STARTUP- FIGURE 2 & 3

The TS7000 display (LMI) will automatically come on when the crane is powered up, the buzzer will sound once then the system will run a CRC (cyclic redundancy check) to make sure that all raw data is correct.

Once the system has completed the CRC the buzzer will sound again, and a set of internal diagnostics (watchdogs) will be utilised to verify that all inputs and outputs are working correctly.

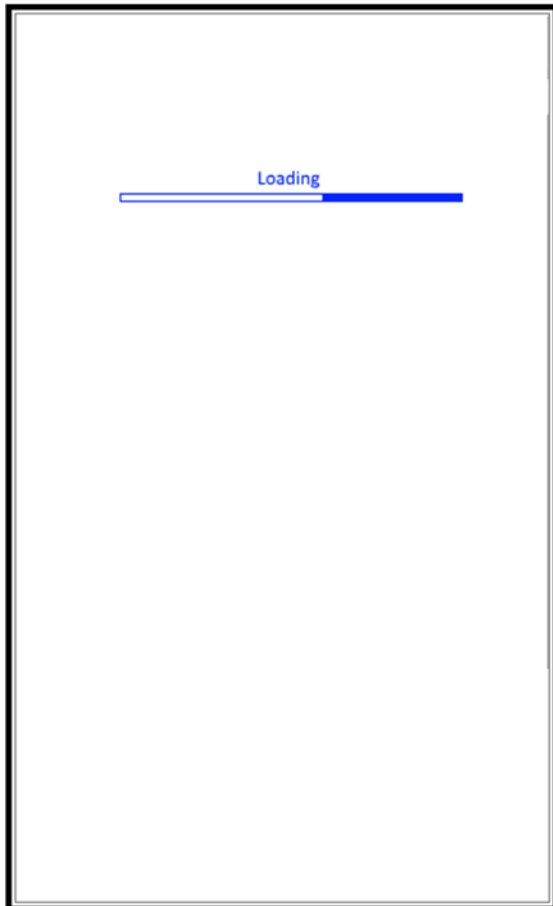

Figure 2

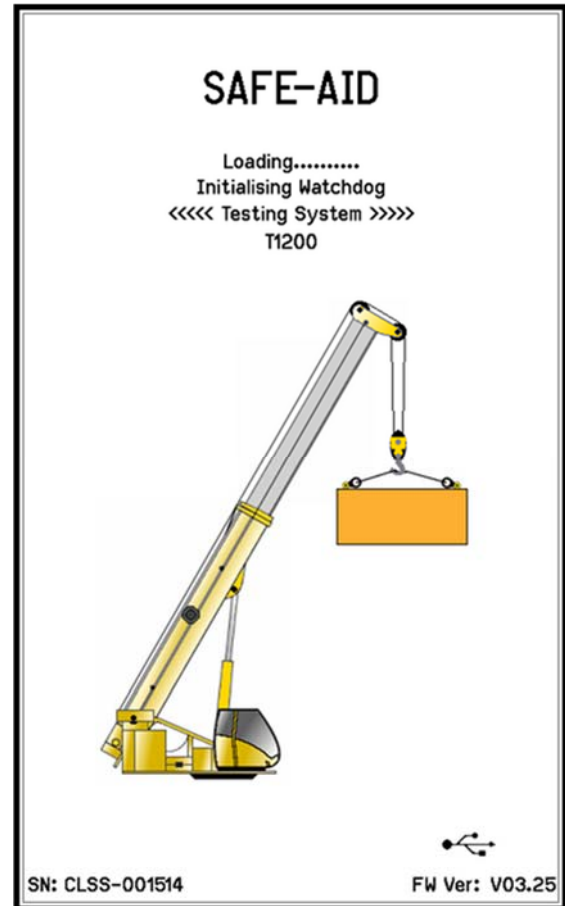

Figure 3

TILT OR LEVEL SET-UP- FIGURE 4

This step will be skipped in the following conditions:

- *No tilt board is fitted*
- *Tilt board is fitted but no tilt values have been entered*

The following option is to determine whether the crane is level along the X & Y axis. Level the machine using the dark black lines running along the axis lines. The machine will be level once the lines are as close to the centre forming a cross. Press the **Exit** button to continue.

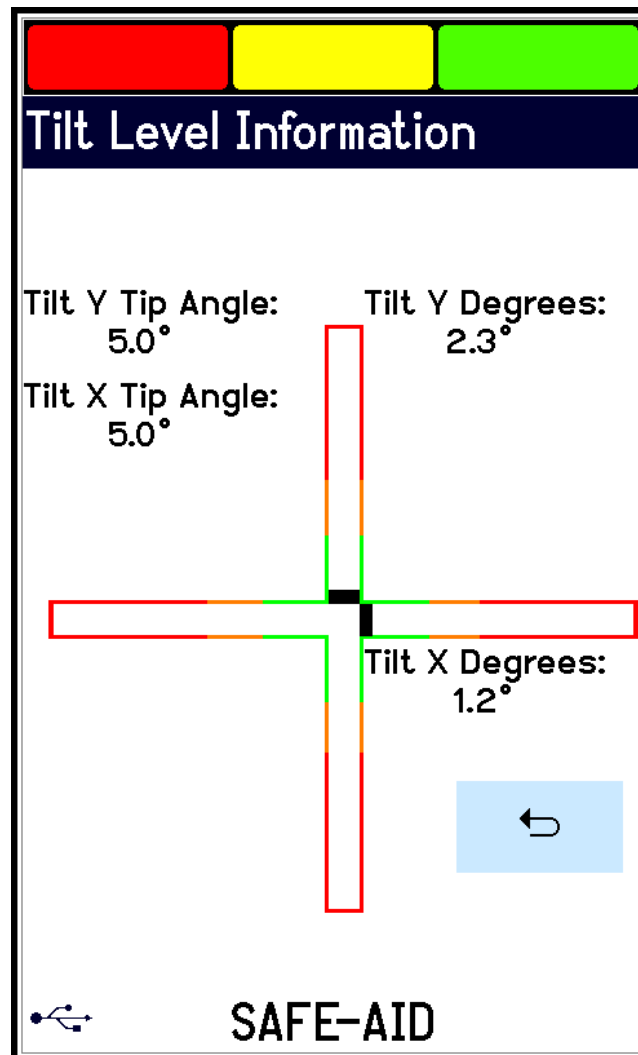

Figure 4

CRANE CONFIGURATION SELECTION

The system will now run through a series of selections to establish the current crane configuration. These selections are setup by the crane manufacturer and correspond to the relevant load chart and may not be displayed or in the same order as laid out in the manual.



Use the back button to start the complete selection from the beginning at any time.

Some manufacturers have telescoping monitoring conditions that may require the boom to be fully retracted before changing the configuration, in this case a **Retract Boom** message will be displayed when trying to change the configuration with the boom extended.

Laid out below are the most common selections available

COUNTERWEIGHT- FIGURE 5

Select the counterweight that is currently in use.

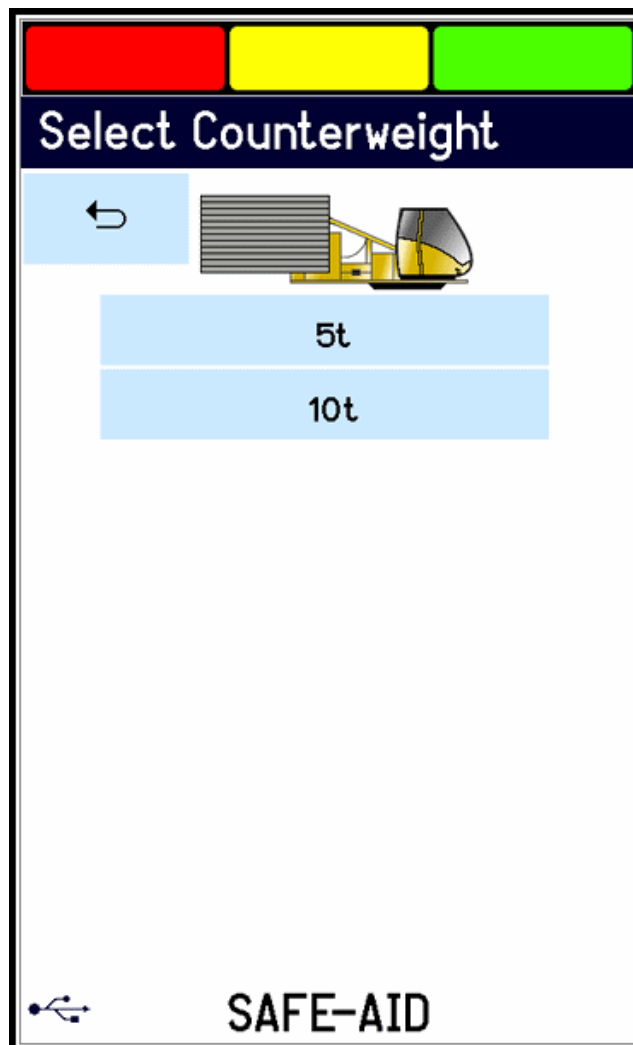

Figure 5

OUTRIGGER BASE- FIGURE 6

Select the outrigger base that is currently in use.

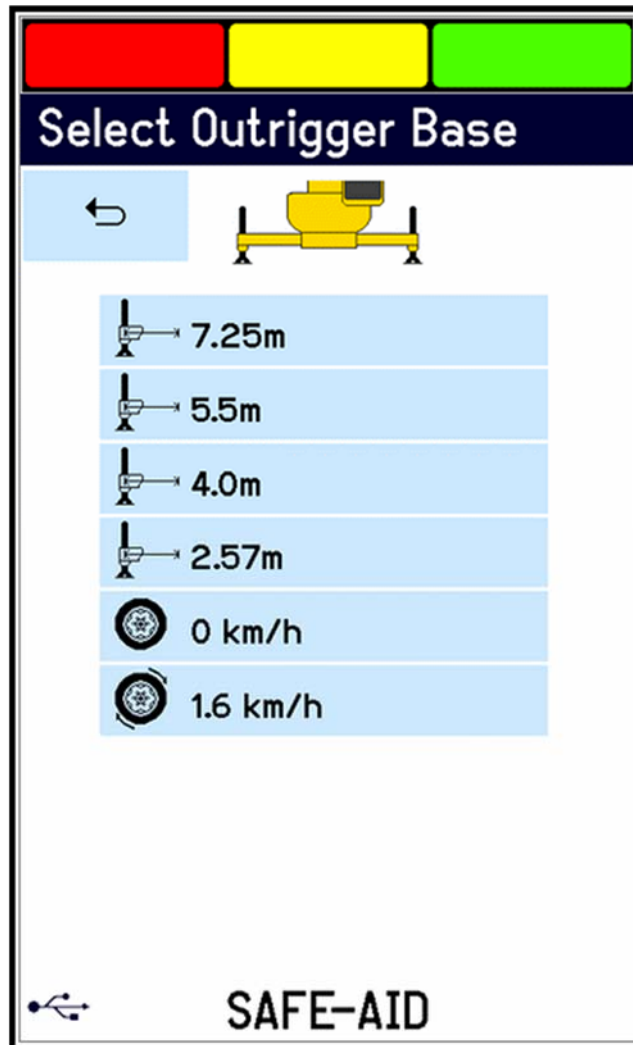

Figure 6

BOOM CONFIGURATION - FIGURE 7

Each boom configuration can be selected by pushing on the configuration that is required. Some manufacturers have telescoping monitoring conditions that may require the boom to be fully retracted before changing configuration, in this case a **Retract Boom** message will be displayed when trying to change the program with the boom extended.

The correct selection of the configuration is imperative as this determines the correct rated capacities and work areas. If selected incorrectly, a higher rated capacity than allowed could be selected for that crane configuration, this is very dangerous as it can cause the boom to bend / break or the crane to tip / fall over.

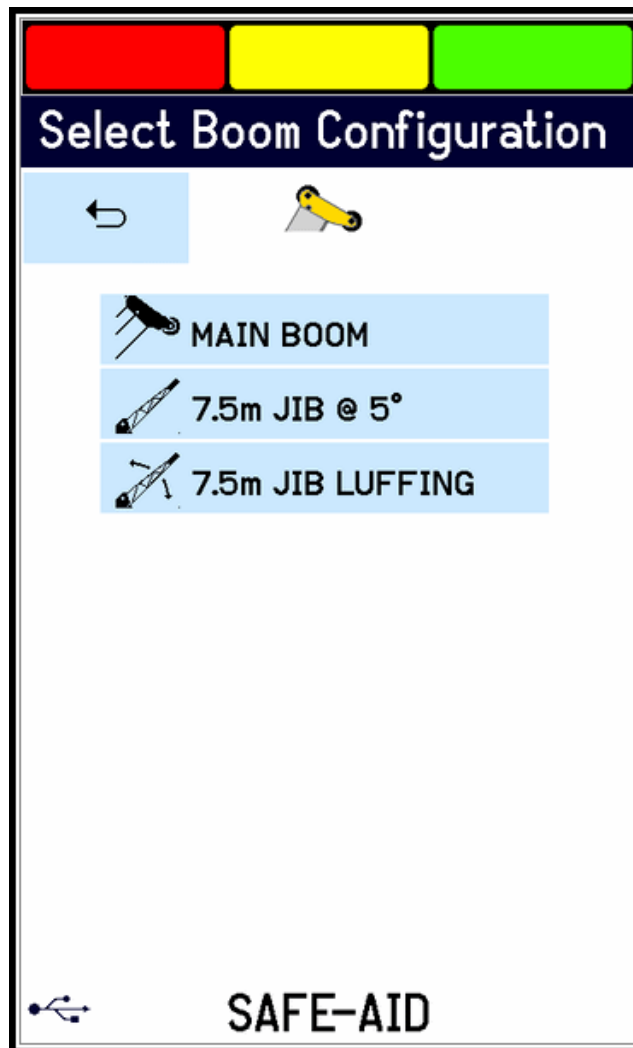

Figure 7

FIFTH OUTRIGGER - FIGURE 8

Truck mount cranes may be fitted with additional outriggers (front jack / rear jack or both) which can be extended (down) or retracted (up). This influences the rated capacities when working over the front or rear of the crane either by decreasing the capacities or giving a slew error when the 5th outrigger is retracted (Figure 3). Simply key the option required - if the 5th outrigger is **down** then select **extended** if it is **up** select **retracted**.

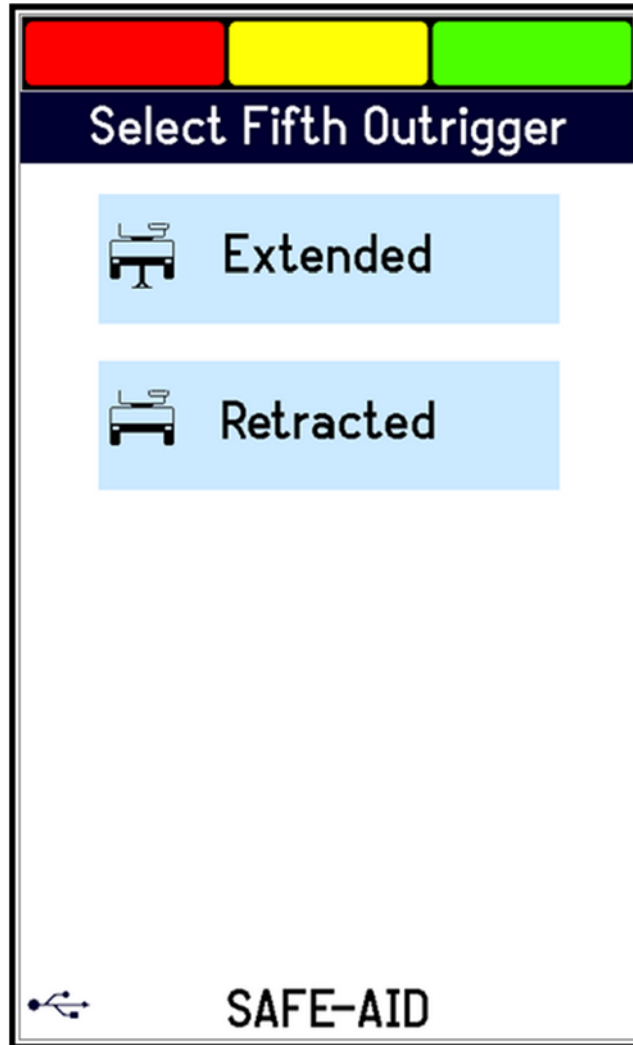

Figure 8

WINCH - FIGURE 9

This step will be skipped in the following conditions:

- ***The system has been programmed with only one winch.***
- ***The reeving has been fixed in rigging mode.***

The following option is to determine the winch being used for lifting. Simply select the option required. Select the relevant winch.

Winch 1 – Main Winch

Winch 2 – Auxiliary Winch

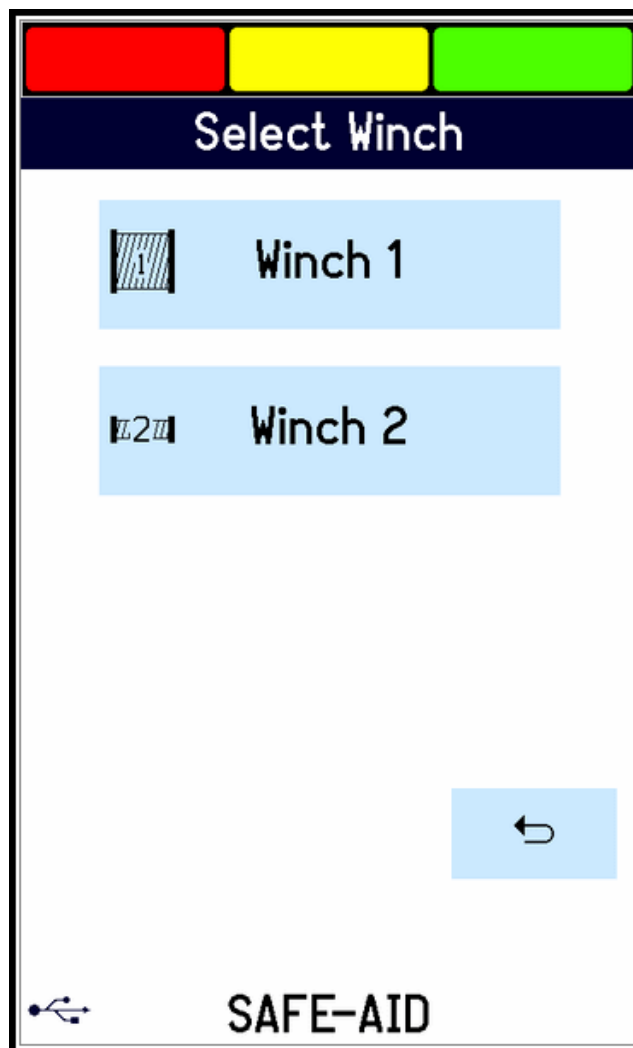

Figure 9



While working in the main running screen and the winch needs to be changed or if an error has been made, press the picture of Winch 1 (main winch) or Winch 2 (auxiliary winch). Select the required winch followed by the correct reeving.

REEVING - FIGURE 10

This step will be skipped in the following conditions:

- **The system has been programmed with fixed reeving.**
- **The reeving has been fixed in rigging mode.**
- **A fixed hook has been selected (cannot be reeved).**

After winch selection, how many reeves (falls) the hook is reeved to (total parts of line between hook block and sheave wheels) must be selected. A numerical keypad will be displayed, key in the number of reeves on the winch (i.e. Winch #1 or Winch #2), followed by

the enter key  (e.g. if Winch #1 (main winch) was selected Select Reeving Winch 1 will

be displayed). If the incorrect number is keyed in simply press the clear button  and start again. Once the enter button is pressed the next selectable option or the operating screen will appear.

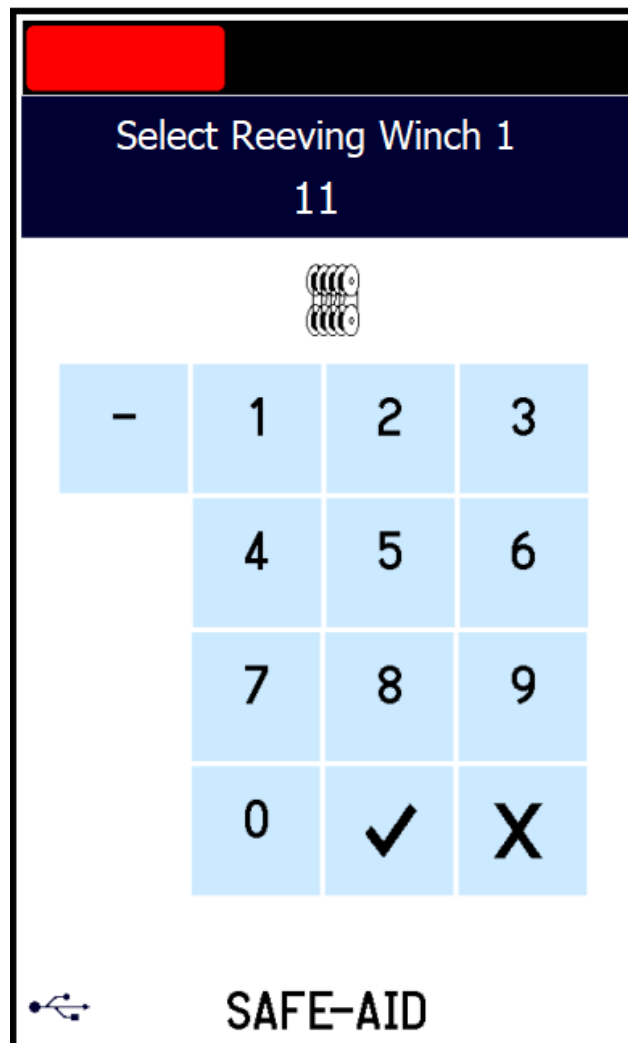
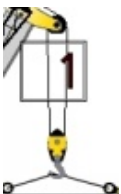

Figure 10



While working in the main running screen or if an error has been made and the reeving needs to be changed, press the block on the main running screen where the winch rope goes down to the lifted load and the system will respond by changing to the Reeving entry screen.

DEDUCTIONS - FIGURE 11

This step will be skipped in the following conditions:

- ***No deductions for the relevant program are available.***

On cranes where the main boom can be used with the fly jib erected or the main hook block is on while the fly jib is being used, the crane manufacturer may give deductions that must be taken off the rated load when using that configuration. The total of all the selected deductions will be automatically deducted from the rated capacity, this is done by the TS7000 once the correct options have been selected when prompted (figure 9). Press the deduction

required and a  will be displayed on the right of the selected deduction, if more than one deduction is required select all the deductions (figure 10). Once all the deductions have been

selected press  to continue.

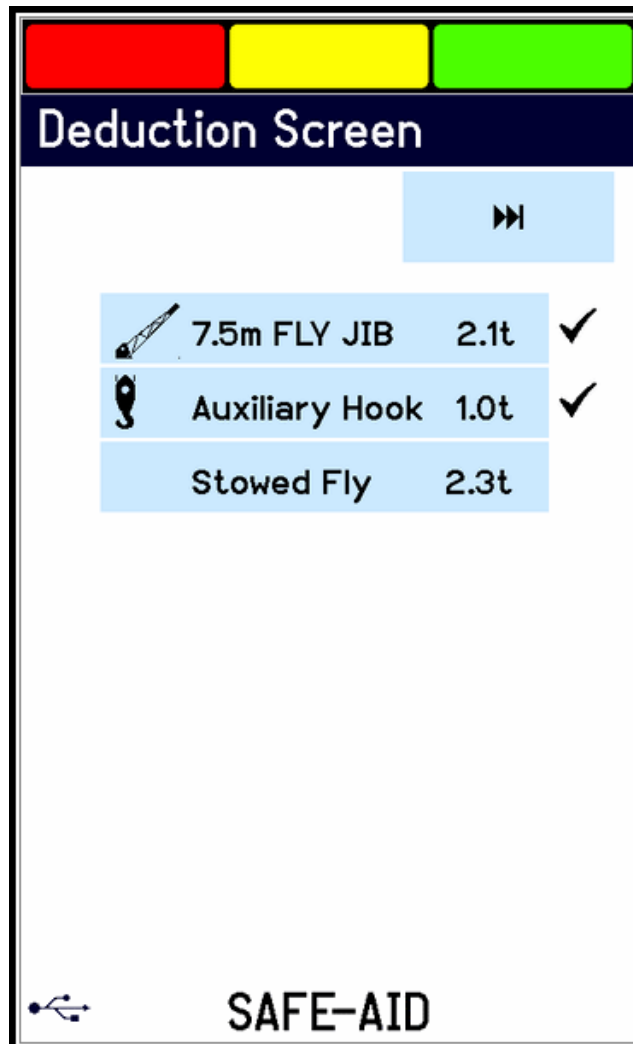

Figure 11

OPERATING SCREENS – FIGURE 12, 13, 14 & 15

All the crane and system information can be viewed from here including all the parameters selected from power up. Should a different program need to be selected, press the crane graphic on the screen, the system will go back to the beginning as on system start up. Repeat the steps above.

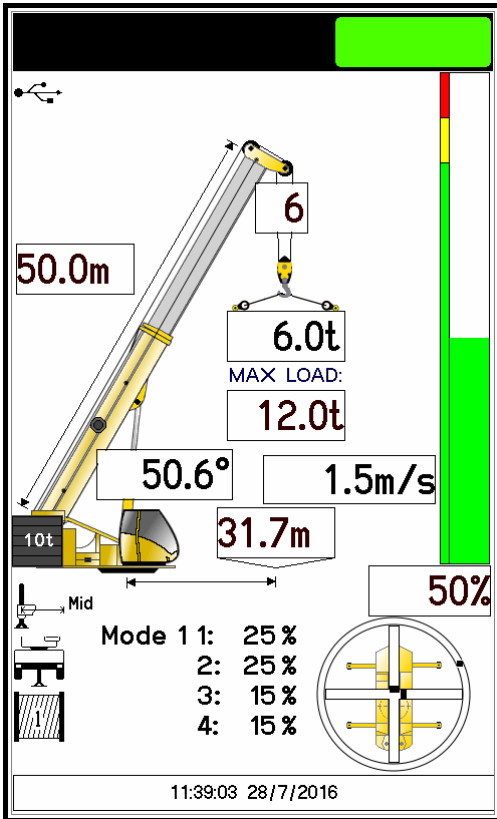

Figure 12

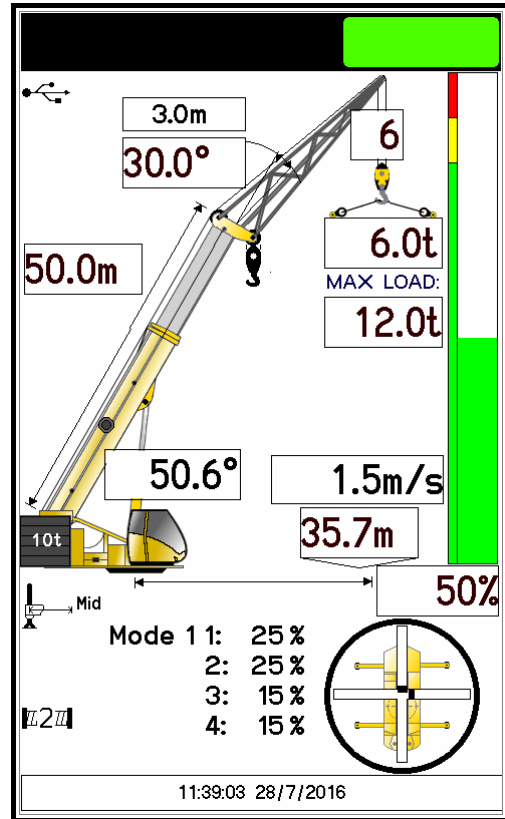

Figure 13

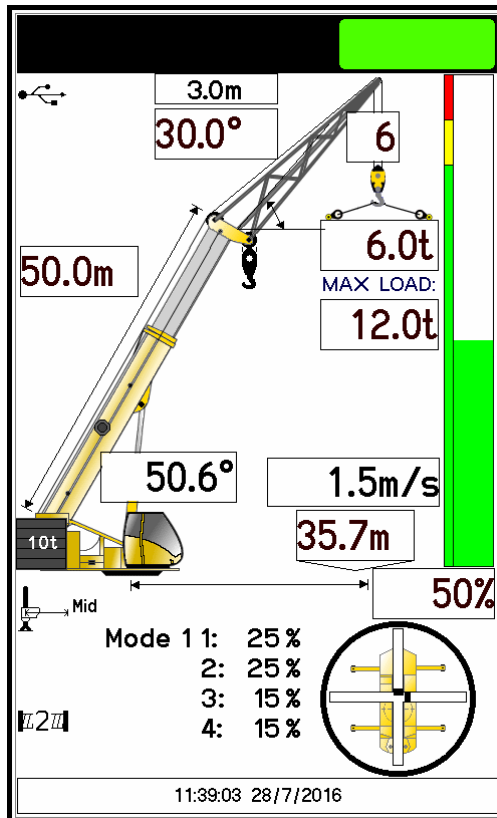

Figure 14

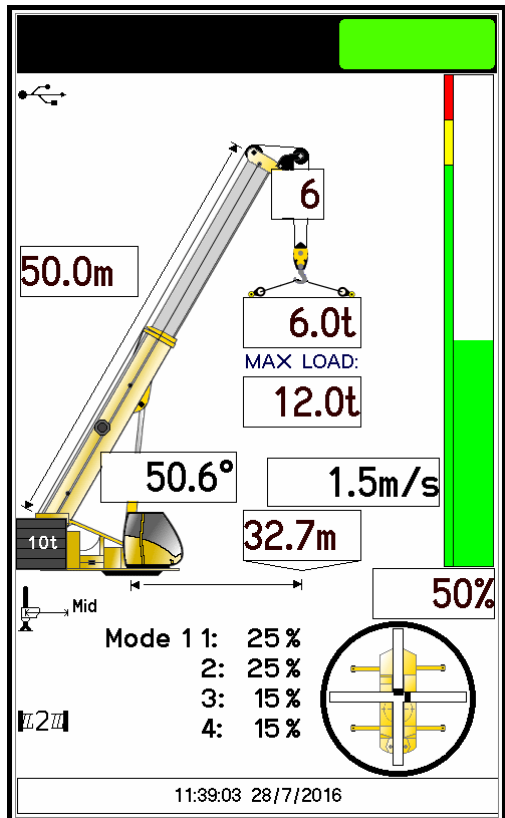
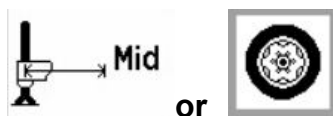

Figure 15

In operating mode, you can see all the current parameters of the crane.



Outrigger Base: This is the current outrigger base – can be represented by the outrigger picture with outrigger length or a picture of a tyre with the crane travel speed.



Fifth Outrigger: This is the fifth outrigger position



Winch: This is the winch selected



Counterweight: This is the total weight of counterweights fitted



Radius: This is the current radius from centre line of rotation to the centre of the hook block (load) if the hook block (load) is suspended and hanging vertical.



Lifted Load: This is the load on the hook at the present time, if the green light and the load are flashing it is a tare load (the tare has been pressed).

MAX LOAD:

12.0t

Rated Capacity: This is the load allowed to be picked up with the selected configuration at that current radius as specified by the manufacturer.



Main Boom Length: This displays the current total main boom length.

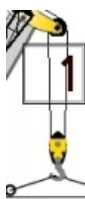

Reeving: This is the current reeving (number of falls) selected.



50.6°

Main Angle: This displays the main boom angle.

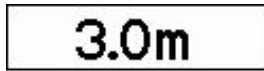

3.0m



Fly Length: This displays the selected or measured fly length.

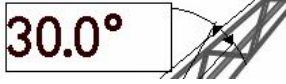

30.0°



Fly Angle: A fixed angle will be shown for a fixed fly and for a monitored fixed fly the angle will change as the fly angle changes. The fixed fly angle is measured relative to the main boom i.e. 0° being straight with the main boom and increasing as the offset to the main boom increases.



30.0°

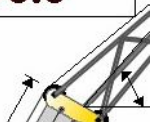

Luffing Fly Angle: If a luffing fly is fitted, the luffing fly angle will be shown in the fly angle box. The luffing fly angle is measured relative to ground level i.e. 0° is the fly jib parallel to the level ground.



50%

Utilisation: Percentage utilisation is the percentage of rated load used by the current lifted load.

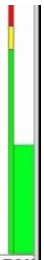

Utilisation Bar: The percentage utilisation is also displayed graphically by a bar graph, going from green (0% - 89%), then amber (90% - 99%) and finally red (100% and above) increasing incrementally with the percentage utilisation.

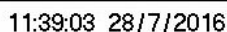

11:39:03 28/7/2016

Date & Time: This is the current date and time.



1.5m/s

Wind Speed: This is the current windspeed (live value) in the units of measure selected.

Mode 1 1: 25 %
2: 25 %
3: 15 %
4: 15 %

Boom Telescope Percentages – This shows the current mode and the boom section percentages.

Area Selection: This is not user selectable and shows the current area the crane is working in:



360 Degrees



Over Side & Rear

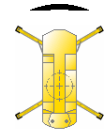

Direct over front



Direct Over Rear

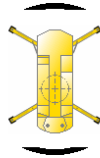

Direct Over Front & Rear



Over Side



Over Front and Side
Outrigger



Over Front Outrigger to Outrigger

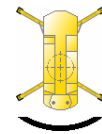

Over Rear Outrigger to

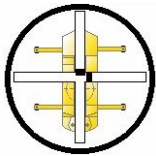

Level/Tilt: The cross through the area selection represents the X & Y axis while the two lines in the axis are the positioning of the crane (see Tilt or Level setup).

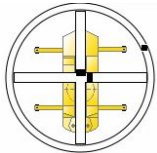

Area Selection Potentiometer: The black dot in the perimeter circle represents the position of the boom relative to the carrier.

ERROR MESSAGES - FIGURE 16 AND TABLE #1

The TS7000 will sound a buzzer and the green block will be replaced by an orange or red block at the top of the screen if any error occurs on the system. These errors are displayed at the bottom of the screen as either an error code only or the error description with the error code e.g. Anti-2-Block E002 where program selection is normally displayed. If more than one error occurs the errors will scroll on the bottom until rectified.

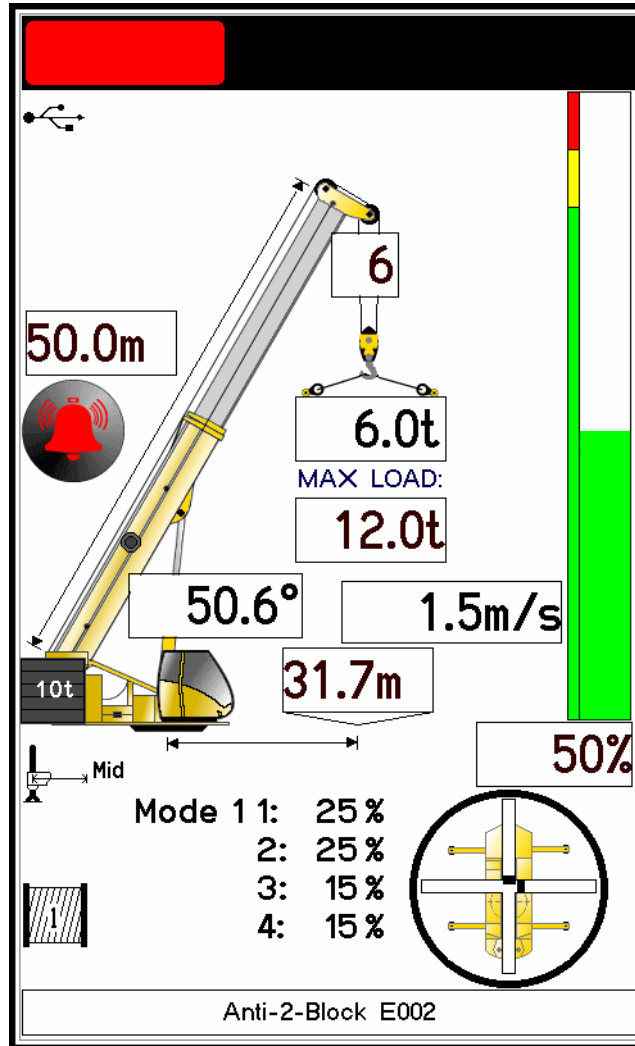

Figure 16

For all the errors, we have given indication of the problem and the common solutions, these can be done by the operator or an individual who has some basic crane knowledge. If the given solution does not work, please contact the original installer or someone from our service network where we can try and help telephonically or send a technician to repair the system.

SAFE-AID TS7000 SYSTEM ERROR TABLE – TABLE #1

CODE	SCREEN DISPLAY	INDICATION	OPERATOR SOLUTION
E001	Slew Error	Boom is not over an area covered by the current configuration selected.	Slew the boom into a safe working area.
E002	Anti-2-Block	The main or auxiliary hook has been pulled up too close to the boom head sheave wheels.	Lower Winch 1 or 2.
E003	Anti-2-Block Fly	The hook has been pulled up to close to the fly jib tip sheave wheel.	Lower Winch
E004	90% Overload	The lifted load is greater than or equal to 90% of the rated capacity	Move load into safe working position - winch down, boom up or retract boom.
E005	Overload	The lifted load is greater than or equal to 100% of the rated capacity	Move load into safe working position - winch down, boom up or retract boom.
E007	Length Exceeded	The length allowed for the selected configuration has been exceeded or the length is greater than maximum manufacturer's specified length.	Retract boom & check configuration selection is correct.
E008	Low Angle	The angle of the boom is below the crane manufacturer's minimum specification.	Raise boom.
E009	Extend Boom	You are working below the specified working length for the selected boom configuration.	Extend boom to the correct working length & check program selection.
E010	Rope Overload	The maximum line pull specified by the manufacturer has been exceeded.	Put Load down – check correct reeving selected.
E025	Telesequence Error	The boom has been telescoped incorrectly NOT according to the manufacturer's specifications.	Retract boom fully and telescope according to the manufacturer's specifications.
E027	Main A400 No Coms	No communication between main angle board and motherboard/display.	Call installer or service technician.
E028	Aux A400 No Coms	No communication between auxiliary angle board and motherboard/display.	Call installer or service technician.
E029	M400 No Coms	No communication between mother board and display.	Call installer or service technician.

CODE	SCREEN DISPLAY	INDICATION	OPERATOR SOLUTION
E031	High Angle	The angle of the boom is above the crane manufacturer's maximum specification.	Lower boom.
E033	R400 No Coms	No communication between relay board and motherboard/display.	Call installer or service technician.
E034	No Load Chart Data	You are working out of the manufactures specified working range – incorrect working radius	Lower Boom to within the manufacturers specified working range.
E035	No Moment Value	Pressure Error	No empty and loaded moment data at specific length and angle.
E036	Tilt Error X Axis	Crane has tilted over maximum allowed tilt on the X axis (Left & right of carrier)	Level crane to within specified tilt range.
E037	Tilt Error Y Axis	Crane has tilted over maximum allowed tilt on the Y axis (Front & rear of carrier)	Level crane to within specified tilt range.
E038	Anti-2-Block Short Circuit	There is a short circuit between the two A-2-B wires.	Call installer or service technician.
E039	Anti-2-Block Fly Short Circuit	There is a short circuit between the two A-2-B wires on the fly jib.	Call installer or service technician.
E040	A400 Tilt No Coms	No communication between A400 Tilt board and motherboard/display.	Call installer or service technician.
E041	O/R Front Left Error	Front Left Outrigger is not extended to the correct length.	Extend Front Left Outrigger to correspond to program selection.
E042	O/R Front Right Error	Front Right Outrigger is not extended to the correct length.	Extend Front Right Outrigger to correspond to program selection.
E043	O/R Rear Left Error	Rear Left Outrigger is not extended to the correct length.	Extend Rear Left Outrigger to correspond to program selection.
E044	O/R Rear Right Error	Rear Right Outrigger is not extended to the correct length.	Extend Rear Right Outrigger to correspond to program selection.
E045	Main Dump Short Circuit	Short circuit on the Main Dump Output.	Call installer or service technician.
E046	Main Dump Open Circuit	Open circuit on the Main Dump Output.	Call installer or service technician.

CODE	SCREEN DISPLAY	INDICATION	OPERATOR SOLUTION
E053	No Dump Supply	No supply (power or ground) on the selected dump supply.	Check 5A dump fuse.
E054	Keyswitch Override – High Side	Override Key has been turned to the override position - key cannot be removed from the switch	Turn override key to position where key can be removed.
E055	Keyswitch Override – Low side	Override Key has been turned to the override position - key cannot be removed from the switch	Turn override key to position where key can be removed.
E056	A400 Windspeed No Coms	No communication between A400 Windspeed board and Main A400/motherboard/display.	Call installer or service technician.
E058	Maximum Windspeed	Maximum wind speed limit specified by the manufacturer has been reached.	Check manufacturers limit has been set correctly.
E062	Raise Fly Jib	Hydraulic off settable fly angle needs to be closer to the selected offset - more towards the minimum offset.	Raise the fly jib towards minimum offset (0° is straight in line with main boom) - check program selection.
E063	Lower Fly Jib	Hydraulic off settable fly angle needs to be closer to the selected offset - more towards the maximum offset.	Lower the fly jib towards maximum offset (45° is 45° below the straight line of the main boom) - check program selection.
E064	2nd Main A400 No Coms	No communication between 2nd Main Angle board and Main A400/motherboard/display.	Call installer or service technician.
E065	P/Tdx Bottom Error	Bottom pressure transducer reading below 3.75mA – 5400 - 5410 counts.	Call installer or service technician.
E066	P/Tdx Top Error	Top pressure transducer reading below 3.75mA – 5400 - 5410 counts.	Call installer or service technician.
E067	Length Error	Length potentiometer is reading below minimum allowed reading - 750-770 Counts.	Call installer or service technician.
E068	Extend Fly jib	Hydraulically extendable fly length is shorter than the selected program.	Extend fly jib to the correct working length – check program selection.
E069	Retract Fly Jib	Hydraulically extendable fly length is longer than the selected program.	Retract fly jib to the correct working length – check program selection.
E070	User Minimum Length Error	Main boom length is less than the user selected minimum length setting.	Extend main boom or clear user selected minimum length.

CODE	SCREEN DISPLAY	INDICATION	OPERATOR SOLUTION
E071	User Maximum Length Error	Main boom length is greater than the user selected maximum length setting.	Retract main boom or clear user selected maximum length.
E072	User Minimum Radius Error	Radius is less than the user selected minimum radius setting	Extend or lower main boom to increase working radius or clear user selected minimum radius.
E073	User Maximum Radius Error	Radius is greater than the user selected minimum radius setting.	Retract or raise main boom to decrease working radius or clear user selected maximum radius.
E074	User Minimum Angle Error	Boom angle is less than the user selected minimum angle setting.	Raise main boom or clear user selected minimum angle.
E075	User Maximum Angle Error	Boom angle is greater than the user selected maximum angle setting.	Lower main boom or clear user selected maximum angle.
E076	A400 Twin Length No Coms	No communication between A400 Twin Length board and Main A400/motherboard/display.	Call installer or service technician.
E077	User Minimum Fly Angle Error	Fly Jib angle is less than the user selected minimum angle setting.	Raise fly jib or clear user selected minimum angle.
E078	User Maximum Fly Angle Error	Fly Jib angle is greater than the user selected maximum angle setting.	Lower fly jib or clear user selected maximum angle.
E079	Winch Underwind Error	Winch has 3 or less turns – minimum layer device	Winch up – if hook cannot reach ground check reeving is correct to load chart
E080	Rigging Mode	Fly Jib angle is greater than the user selected maximum angle setting.	Lower fly jib or clear user selected maximum angle.

WORKING OPERATIONS – FIGURE 17 & 18

There are **TEN** different touch areas on the operating screen which can be pressed to initiate a function.

1. **Configuration selection** is the crane graphic on the screen. If at any given time, the current configuration needs to be changed, press on the crane graphic and this will return to the first selection as if powering up for the first time. For example, if working main boom on outriggers and now required to work on tyres, immediately change the configuration to on tyres as the cranes rated capacities and limits will be different.

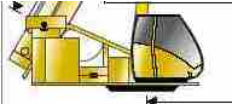

Note: In certain circumstances Program Lockout, has been enabled. See program lockout.

2. While working in the main running screen or if an error has been made and the reeving needs to be changed, press the block on the main running screen where the winch rope goes down to the lifted load and the system will respond by changing to the Reeving entry screen.



3. While working in the main running screen and the winch needs to be changed or if an error has been made, press the picture of Winch 1 (main winch) or Winch 2 (auxiliary winch). Select the required winch followed by the correct reeving.



4. **The buzzer override** which is in the **left centre** of the screen; buzzer override will only be displayed 5 seconds after an error condition occurs. When the buzzer override is pressed, the AMBER BLOCK will flash intermittently, and a red cross will be placed through the picture of the buzzer and the buzzer will shut off.



The buzzer override is needed for each alarm condition i.e. if one error has been overridden and another occurs the buzzer will sound again.

5. **The Tare** which is activated by pressing directly on the lifted load when a load is displaying on the hook. The Lifted Load will be zeroed allowing for a reading excluding the original weight. The original weight is still considered when calculating the percentage of utilization therefore the TS7000 will still give the correct 90% and 100% warnings. Once pressed the numbers under the lifted load will flash showing no value, only 0,0t and the GREEN BLOCK will flash intermittently. Thereafter, if a load is lifted, only the load lifted will be displayed and not the load together with hook block or any other additional weight. To return to the actual load, press the lifted load again, it will stop flashing showing the actual load on the hook.



6. **Wind Speed** – Press on the wind speed block to enter the wind speed setup (see Wind Speed Setup).

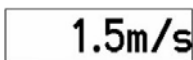

7. **The momentary override** which is the utilisation bar graph on the screen. By holding your finger anywhere in this area, the dump solenoids (lever cut-off) can be overridden momentarily (while pushing on the screen in that area) to allow the crane to be folded up.



Note: This function can only be used if activated by the installer.

8. **Password Access** - This is accessed by pressing the top left-hand corner. Once pressed a password screen will be displayed, enter the relevant password to access the required menu. To exit and return to the operator's screen press **Enter** button. Screen Brightness access is accessed from this menu, see **Screen Brightness**.

Note: This function can only be used if fitted & activated by the programmer/installer.

9. **User Limit Setup** – Press the screen in the bottom left-hand corner to access the User Limit Setup screen (Figure 17). Highlight the required limit to be set by pressing on the description, press the Select button to access the keypad and type in the limit that is required. Once all the limits have been set press the Back button to return to the working screen. To disable the limit, highlight the limit by pressing on the description and press the **Disable Selected** button this will then put Disabled next to the description and the limit will now be disabled. To disable all limits, press the **Disable All** button.

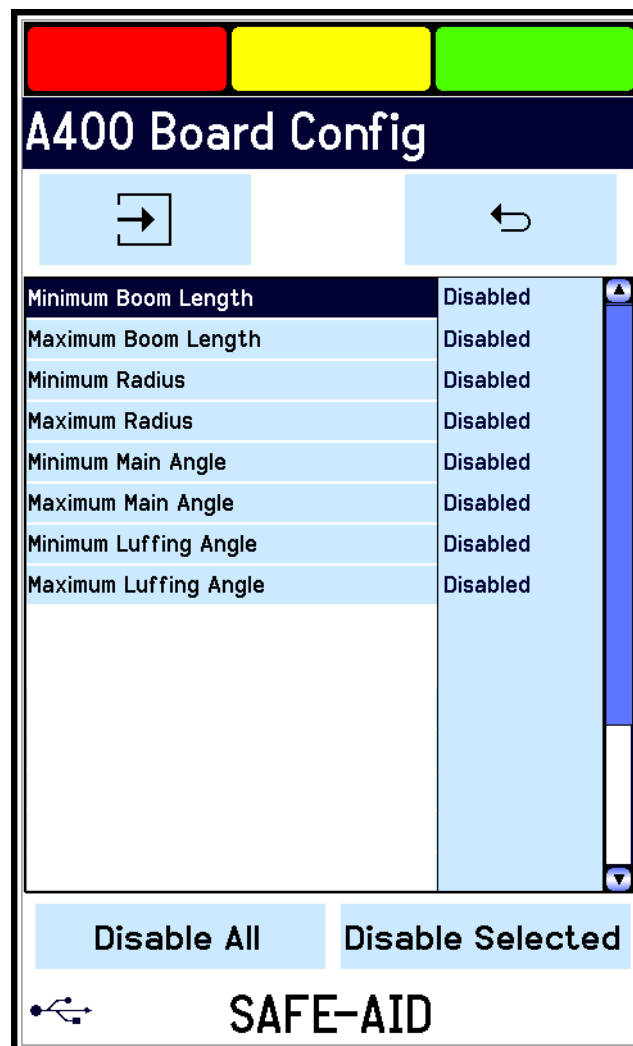

Figure 17

10. Boom Telescope Percentages – To view the current boom percentages and lengths press the working screen where the percentages are displayed. The boom telescope percentage screen will be displayed (Figure 18) with current lengths and percentages. To exit back to the normal working screen, press anywhere on the screen.

- Mode 1: 25%
- 2: 25%
- 3: 15%
- 4: 15%

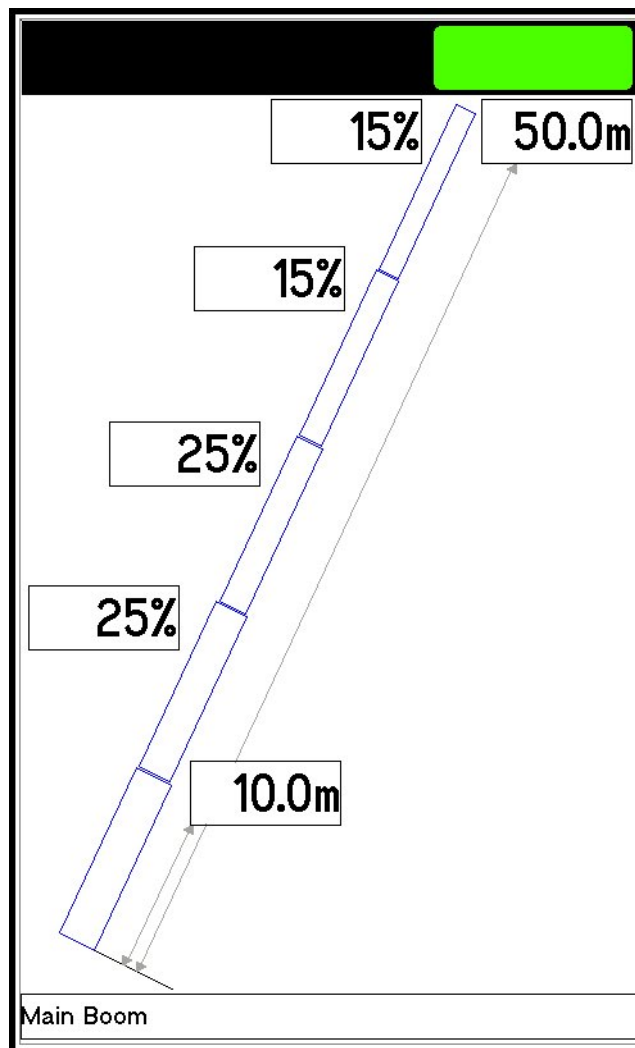

Figure 18

INDICATING STATUS LIGHTS - DUMP OUTPUT (LEVER CUT-OFF) - TABLE # 2

There are **Three BLOCKS** (RED, YELLOW & GREEN) that are illuminated like a traffic robot situated on the top of the display screen.



These BLOCKS are illuminated depending on the working state and error conditions. These BLOCKS are a basic way of checking the LMI.

The following chart gives the BLOCK status, buzzer status as well as the status of the DUMP (Lever Cut-off) i.e. DUMP ON the crane will cut-out and DUMP OFF the crane is able to work. To rectify or check the error, please check the error message chart (Table 1) on page 14 & 15.

The GREEN BLOCK will be permanently on when the system is in the correct working condition i.e. no errors

CODE	SCREEN DISPLAY	BLOCK STATUS	DUMP STATUS	BUZZER STATUS
E001	Slew Error	RED	ON	ON
E002	Anti-2-Block	RED	ON	ON
E003	Anti-2-Block Fly	RED	ON	ON
E004	90% Overload	YELLOW	OFF	INTERMITTENT
E005	Overload	RED	ON	ON
E007	Length Exceeded	RED	ON	ON
E008	Low Angle	RED	ON	ON
E009	Extend Boom	YELLOW	OFF	INTERMITTENT
E010	Rope Overload	RED	ON	ON
E025	Telesequence Error	RED	ON	ON
E027	Main A400 No Coms	RED	ON	ON
E028	Aux A400 No Coms	RED	ON	ON
E029	M400 No Coms	RED	ON	ON
E031	High Angle	RED	OFF	ON
E033	R400 No Coms	RED	ON	ON
E034	No Load Chart Data	RED	OFF	ON

CODE	SCREEN DISPLAY	BLOCK STATUS	DUMP STATUS	BUZZER STATUS
E035	No Moment Value	RED	ON	ON
E036	Tilt Error X Axis	RED	ON	ON
E037	Tilt Error Y Axis	RED	ON	ON
E038	Anti-2-Block Short Circuit	RED	ON	ON
E039	Anti-2-Block Fly Short Circuit	RED	ON	ON
E040	A400 Tilt No Coms	RED	ON	ON
E041	O/R Front Left Error	RED	ON	ON
E042	O/R Front Right Error	RED	ON	ON
E043	O/R Rear Left Error	RED	ON	ON
E044	O/R Rear Right Error	RED	ON	ON
E045	Main Dump Short Circuit	RED	ON	ON
E046	Main Dump Open Circuit	RED	ON	ON
E053	No Dump Supply	RED	ON	ON
E054	Keyswitch Override – High Side	RED	ON	ON
E055	Keyswitch Override – Low side	RED	ON	ON
E056	A400 Windspeed No Coms	RED	ON	ON
E058	Maximum Windspeed	RED	OFF	ON
E062	Raise Fly Jib	YELLOW	OFF	INTERMITTENT
E063	Lower Fly Jib	YELLOW	OFF	INTERMITTENT
E064	2nd Main A400 No Coms	RED	ON	ON
E065	P/Tdx Bottom Error	RED	ON	ON
E066	P/Tdx Top Error	RED	ON	ON
E067	Length Error	RED	ON	ON
E068	Extend Fly jib	YELLOW	OFF	INTERMITTENT
E069	Retract Fly Jib	YELLOW	OFF	INTERMITTENT
E070	User Minimum Length Error	YELLOW	OFF	INTERMITTENT

CODE	SCREEN DISPLAY	BLOCK STATUS	DUMP STATUS	BUZZER STATUS
E071	User Maximum Length Error	YELLOW	OFF	INTERMITTENT
E072	User Minimum Radius Error	YELLOW	OFF	INTERMITTENT
E073	User Maximum Radius Error	YELLOW	OFF	INTERMITTENT
E074	User Minimum Angle Error	YELLOW	OFF	INTERMITTENT
E075	User Maximum Angle Error	YELLOW	OFF	INTERMITTENT
E076	A400 Twin Length No Coms	RED	ON	ON
E077	User Minimum Fly Angle Error	YELLOW	OFF	INTERMITTENT
E078	User Maximum Fly Angle Error	YELLOW	OFF	INTERMITTENT
E079	Winch Underwind Error	RED	OFF	ON
E080	Rigging Mode	YELLOW	OFF	OFF

NOTES:

- The **YELLOW BLOCK** will flash when buzzer override is activated, and if a new error occurs the buzzer will be reactivated and must be overridden again.
- The **green BLOCK** will flash when TARE function is used and the crane is within the limits specified by the manufacturer, if not normal errors will resume.

TOUCH SCREEN CALIBRATION – FIGURES 19, 20 & 21

If the touch screen is not responding correctly to touch the touch screen may need to be calibrated.

Switch the TS7000 system power off then power up the TS7000 and wait for the splash screen (Figure 19) to appear.

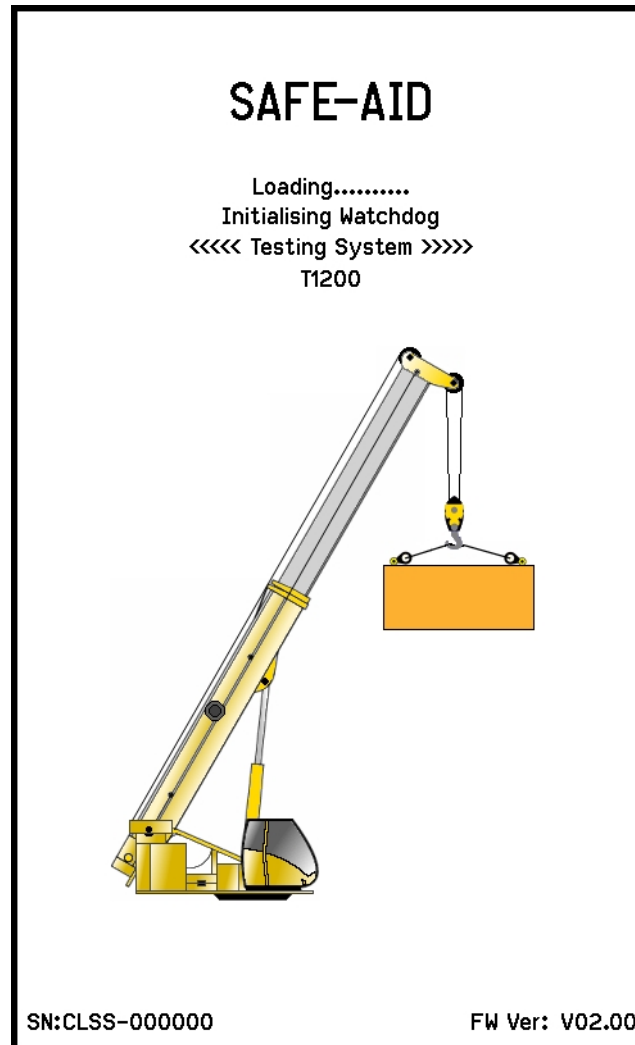

Figure 19

While the splash screen is on, press and hold the screen for five full seconds in the centre until the touch calibration is activated and loaded (Figure 20).



Figure 20

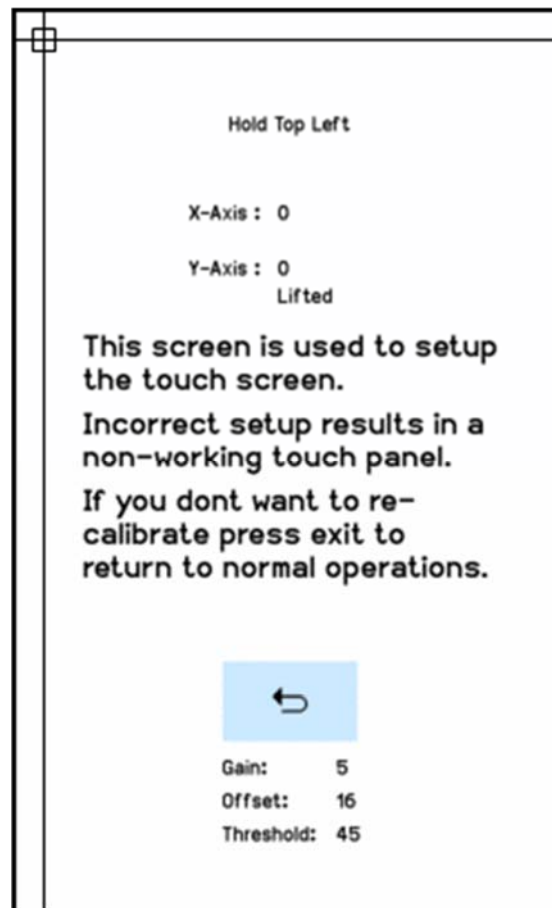

Figure 21

If the calibration screen has been entered by accident and touch calibration is not necessary, press the **Exit** button without pushing anywhere else on the screen. This process exits the touch screen calibration and continues with the standard start up procedure.

If touch calibration is required, follow the below procedures:

Press and hold finger where the two lines meet inside the small box (Figure 21) top-left hand corner). Calibration works fine when using a finger but for better results use a pen taking care not to press too hard or the screen will be damaged.

Hold finger/pen in this area until prompted to lift (Figure 20). The software will then prompt for three more touch zones resulting in co-ordinates for all four corners of the screen.

Once calibration is completed the software automatically begins the standard start up procedure.

WIND SPEED SETUP – FIGURES 22, 23 & 24 – OPTIONAL

Live wind speed is shown on the screen permanently (figure 22) but the units of measure and the maximum wind speed can be adjusted on the screen using the following steps:

1. To access the wind speed menu from the operating screen, press the block where the current wind speed is displayed, a **Password** screen will be displayed (figure 23).
2. Enter the password [- - -] followed by the  button the Set Limit screen will be displayed (figure 24).

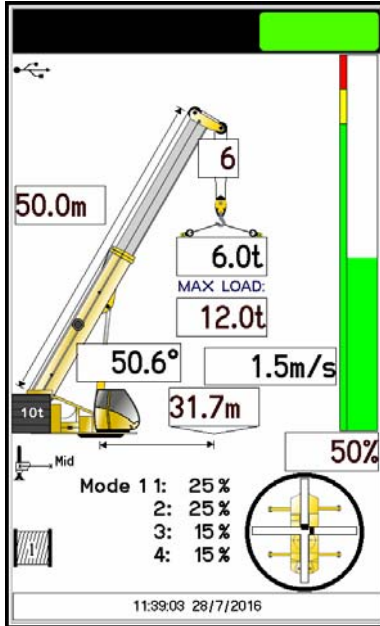

Figure 22

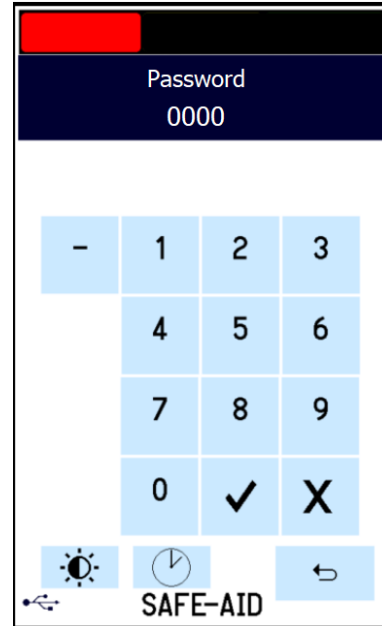



Figure 23

3. Change the units of measure by pressing the blue area of the screen where Set Limit and the limit value are written. The units of measure will change each time the area is pressed i.e. m/s – meters / second, kts - knots, mph – miles / hour and km/h – kilometers / hour.
4. Once you have selected the correct units of measure use the keypad to type in the limit value required then press .

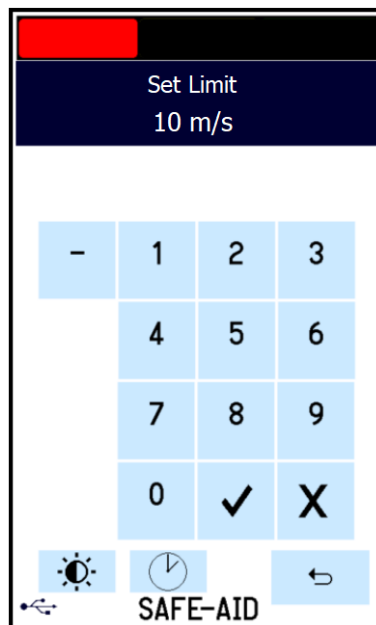



Figure 24

PROGRAM & REEVING LOCKOUT - FIGURES 25, 26, 27 & 28

Programs and reeving can be locked (fixed) to only allow one or two programs and or locking the reeving of each winch.

Use the following steps to lockout programs as required:

1. Press the top left-hand corner and the **Password** screen will be displayed (figure 25).

2. Enter the four digit password [- - -] followed by the  button, the Program Lockout screen will be displayed (figure 26).

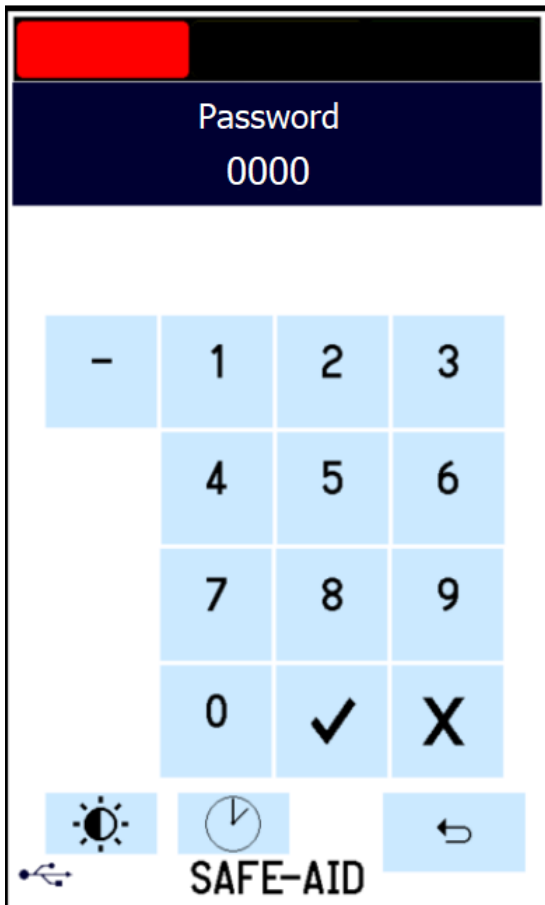

Figure 25

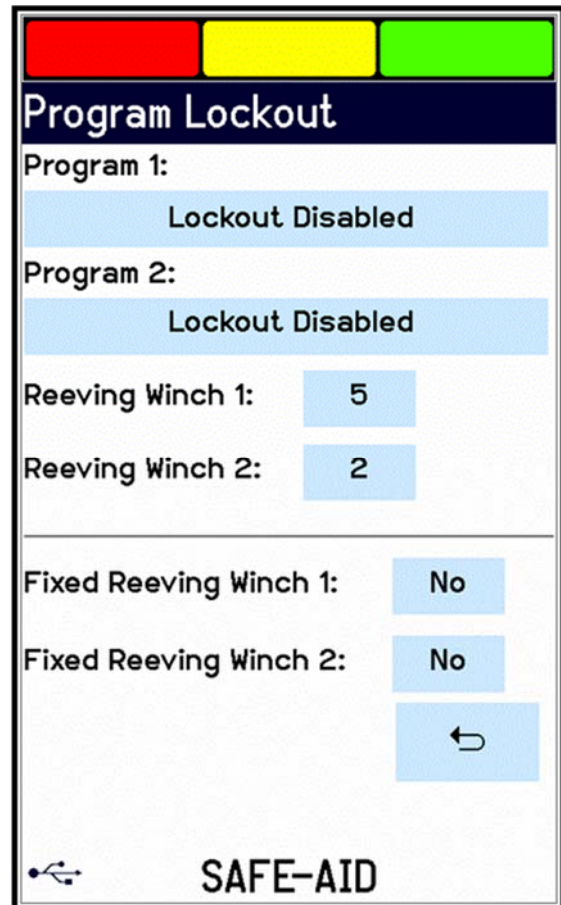





Figure 26

3. To lock or cancel a locked program select the button below Program 1 or Program 2, **Enable Lockout** screen (figure 27) will be displayed.

4.  Select **No** - the screen will return back to the Program Lockout screen and **Lockout Disabled** will be displayed in the selected button (figure 26). Repeat this for Program 1 & 2 if all programs are to have access. If only one program is locked the other will display 

5.  Select **Yes** – the system will now run through the complete program selection to select the program to be locked – an abbreviated description will be displayed once complete (figure 28) Repeat this for the second program if required.

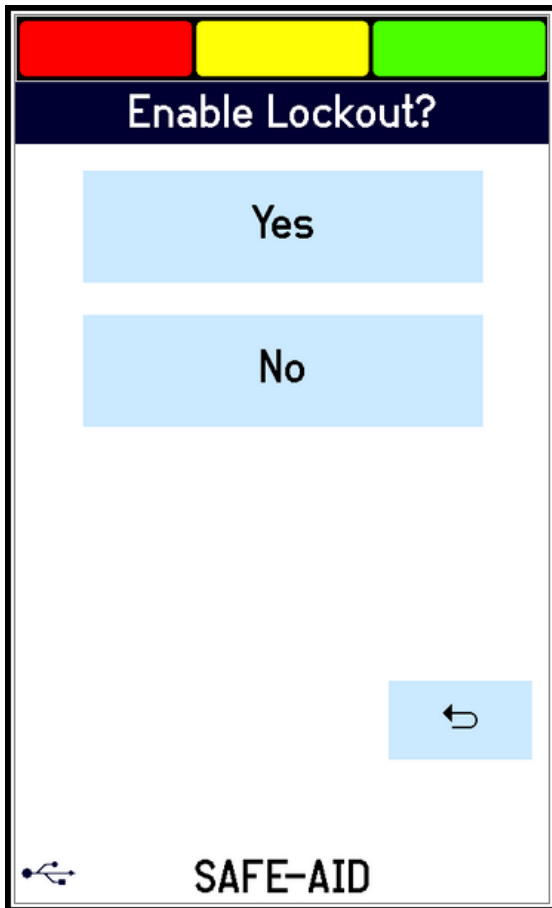

Figure 27

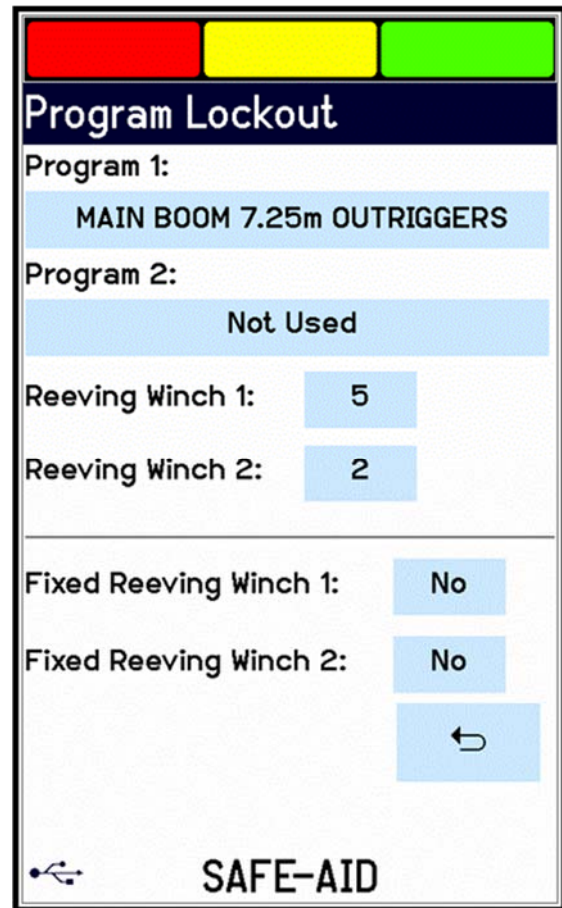

Figure 28

Use the following steps to lockout reeving per winch as required:

1. Press the top left-hand corner and the **Password** screen will be displayed (figure 25).
2. Enter the four digit password [- - -] followed by the **Enter** button, the Program Lockout screen will be displayed (figure 26).

3. **Reeving Winch 1:** To fix the reeving, set the required winch reeving to the fixed number of reeves required. Repeat this for winch 2 if required.

4. **Fixed Reeving Winch 1:** To fix the reeving to the number previously set, press on the button next to the required winch to change from **No** to **Yes**.

5. **Fixed Reeving Winch 2:** To allow the reeving to be user selectable, press on the button next to the required winch to change from **Yes** to **No**.



Once all the Lockout settings have been confirmed press the **Back** button to return to the operating screen.

SCREEN BRIGHTNESS – FIGURES 29 & 30

The screen backlight can be set as required.

Use the following steps to adjust the screen brightness:

1. Press the top left-hand corner and the **Password** screen will be displayed (figure 29).

2. Press the  and the Brightness adjust screen (figure 27) will be displayed. Use the slider bar to adjust the screen to the required brightness.

3. Once the brightness has been adjusted press the  button to return to the operating screen.

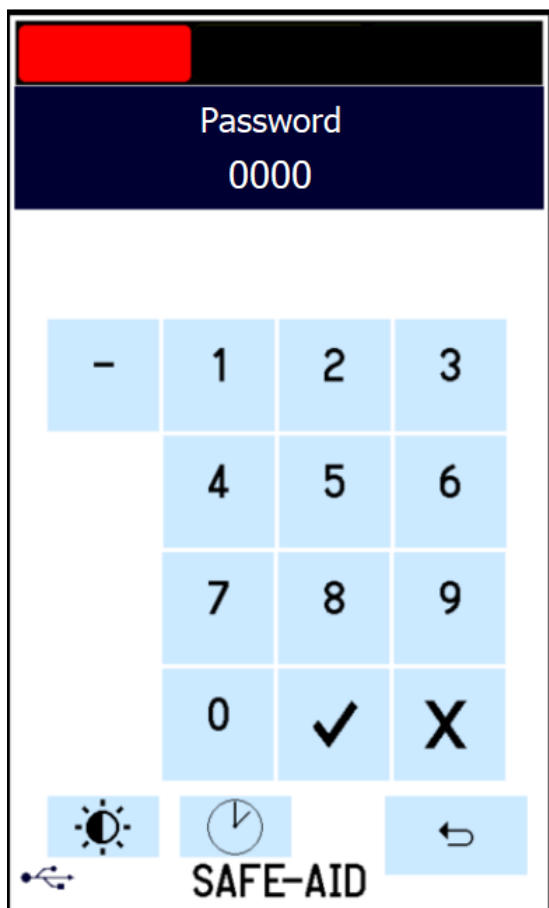

Figure 29

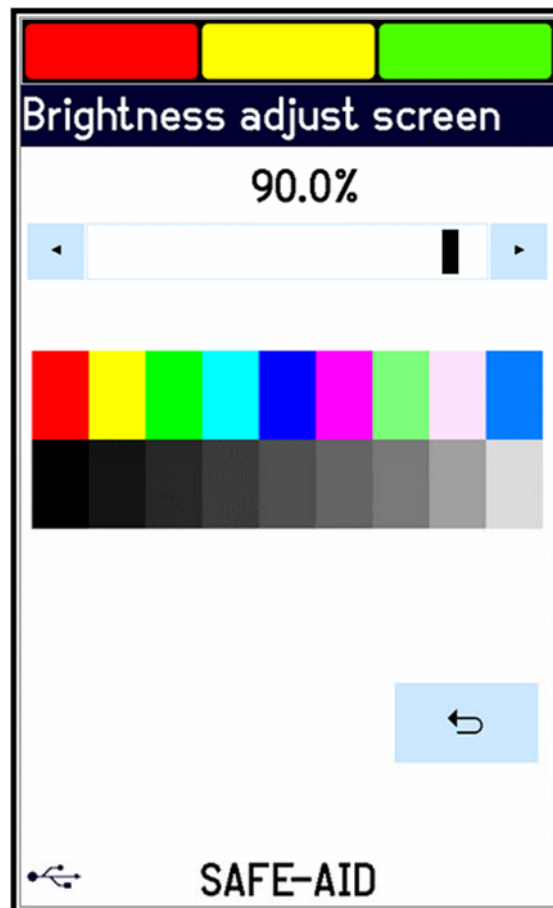

Figure 30

SET DATE & TIME - FIGURES 31 & 32

The date and time can be adjusted as required, if the date and time does not save the battery for the real time clock is no longer working (see Real Time Clock battery replacement).

Use the following steps to adjust the date & time:

1. Press the top left-hand corner and the **Password** screen will be displayed (figure 31).



2. Press the  and the Set Date & Time screen (figure 32) will be displayed. Select the data to be adjusted and set the correct time and date.
3. Time format is 24 Hour Clock hh : mm : ss
4. Date format is dd / mm / yyyy



5. Once the time & date have been adjusted press the  button to return to the operating screen.

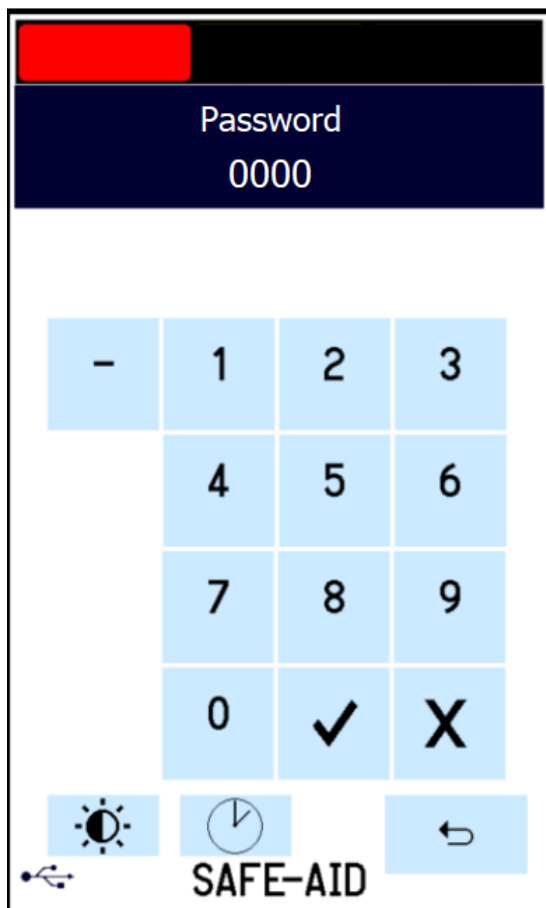

Figure 31

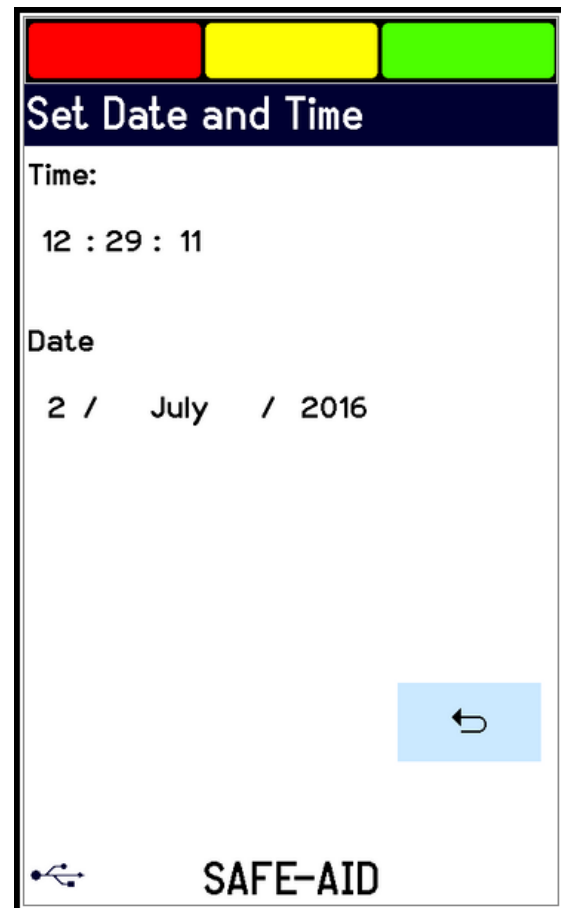

Figure 32

QUICK USE FLOW CHART

